

SLIDING DOORS
PINZA model



The PINZA model lends the maximum elegance and visibility of the interior to entrances. It is designed for doorways where, for aesthetic reasons, frames must be avoided and bare glass is the best option. This model is ideal for interior entrances and for offices in particular.

2 installation solutions are available: with a top and bottom frame or with a top frame and bare glass at the bottom.

Panes from 4+4 to 6+6 can be installed and they are secured with special silicone.

The model is supplied with a specially designed plastic cover to ensure that the leaves meet smoothly, leaving a small gap to prevent the panes from knocking against each other and enhancing the look of the clip.



PINZA FRAME

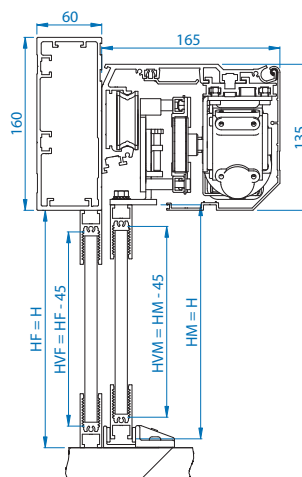
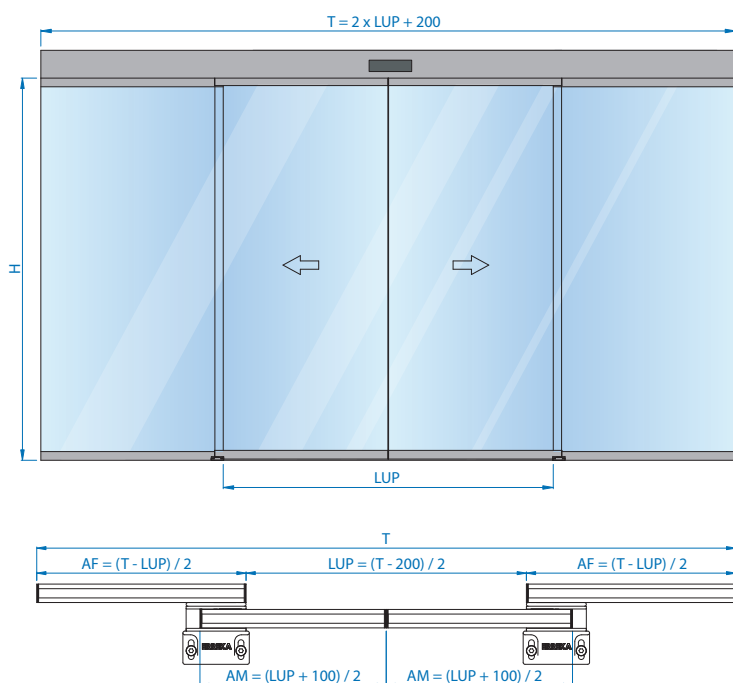

PINZA

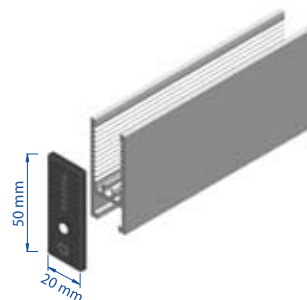

CONFIGURATIONS

OPERATORS	NUMBER OF LEAVES	FINISHES
Universal	1 moving + 0 fixed	Lacquered: all RAL colours Anodised: silver, bronze, black, gold matt, titanium and special anodising Stainless steel: quality 304, 316 in satin, gloss and polished with emery
	2 moving + 0 fixed	
Ertain	1 moving + 1 fixed	
	2 moving + 2 fixed	
Telescopic	4 moving + 0 fixed	
	4 moving + 2 fixed	
	2 moving + 1 fixed	